

REGADERA SPACIO DE CHORRO FIJO
CON SISTEMA ANTICALCAREO

REC-SP-01

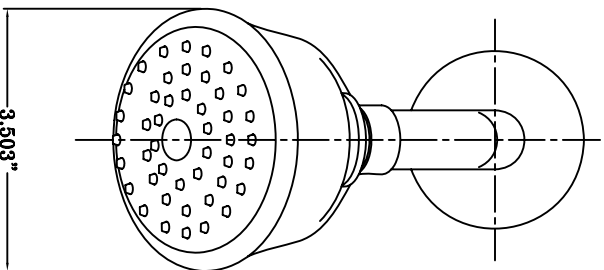
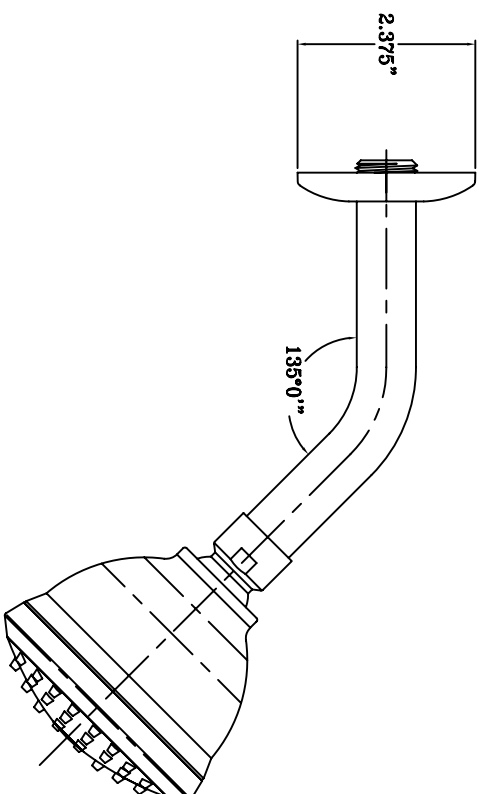
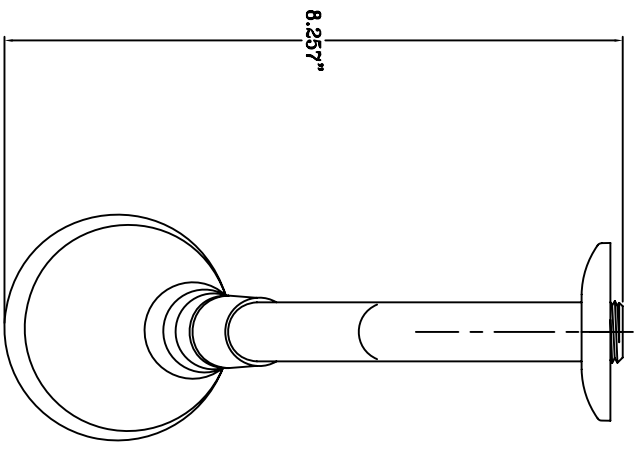

4	1-00-0354	INSTRUCTIVO GARANTIA P/VIDA IMP.	1
3	1-00-0348	ETIQUETA MARCA PROYECTA 8,4 X 7 cm	2
2	1-00-0083	ETIQUETA P/CODIGO DE BARRAS 3" X 2"	1
1	2-08-0901	REGADERA C/ANTICALCAREO INTERMEDIA	1
N°	CLASIFICACION	DESCRIPCION	CANT.